



CQD12SSD

Electric Reach Truck 1.2t

Standing type double scissors fork forward forklift

EP EQUIPMENT CO.,LTD
www.ep-ep.com

Electric Reach Truck 1.2t

CQD12SSD

Distinguishing mark				
1.1	Manufacturer			EP
1.2	Model designation			CQD12SSD
1.3	Drive unit			Battery
1.4	Operator type			standing
1.5	rated capacity	Q	t	1.2
1.6	Load center distance	c	mm	600
1.9	Wheelbase	y	mm	1573
Weight				
2.1	Service weight (include battery)		kg	2675 ^①
2.2	Axle loading, fork advanced, unladen driving side/loading side		kg	1645/1108
2.3	Axle loading, fork retracted, unladen driving side/loading side		kg	1942/935
2.4	Axle loading, fork advanced, laden driving side/loading side		kg	547/3286
2.5	Axle loading, fork retracted, laden driving side/loading side		kg	1506/2355
Types,Chassis				
3.1	Tyre type driving wheels/loading wheels			polyurethane/polyurethane
3.2	Tyre size, driving wheels (diameter×width)		mm	Φ260× 105
3.3	Tyre size, loading wheels (diameter×width)		mm	Φ102× 73
3.4	Tyre size, caster wheels (diameter×width)		mm	Φ178×73
3.5	Wheels, number driving, caster/loading (x=drive wheels)		mm	1×, 2/4
3.6	Track width, front,driving side	b10	mm	520
3.7	Track width,rear,loading side	b11	mm	1178
Dimensions				
4.1	Tilt of mast/fork carriage forward/backward	α/ β	°	2/4
4.2	Height, mast lowered	h1	mm	2070 ^②
4.3	Free lift (load backrest)	h2	mm	0 ^②
4.4	Lift height	h3	mm	3000 ^②
4.5	Height, mast extended	h4	mm	3940 ^②
4.7	Height of overhead guard (cabin)	h6	mm	2250
4.8	Seat height/standing height	h7	mm	343
4.10	Height of wheel arms	h8(mm)	mm	130
4.19	Overall length (minimum)	l1	mm	2535 ^③
4.20	Length to face of forks	l2	mm	1470
4.21	Overall width	b1/ b2	mm	1078/1278
4.22	Fork dimensions	s/ e/ l	mm	40/100/1070
4.23	Fork carriage class/type A, B		mm	A
4.24	Fork carriage width	b3	mm	800
4.25	Distance between fork-arms	b5	mm	200-780
4.26	Distance between wheel arms/loading surfaces	b4	mm	1078
4.28	Reach distance	l4	mm	1000
4.31	Ground clearance, laden, below mast	m1	mm	50
4.32	The minimum ground clearance of frame	m2	mm	50
4.34.1	Aisle width for pallets 1000 × 1200 crossways	Ast	mm	2906 ^③
4.34.2	Aisle width for pallets 800 × 1200 lengthways	Ast	mm	2955 ^③
4.35	turning radius	Wa	mm	1845
4.37	Length across wheel arms (exclusive fork)	l7	mm	1975
Performance data				
5.1	Travel speed, laden/ unladen		km/ h	8.5/9
5.2	Lifting speed, laden/ unladen		m/ s	0.26/0.39
5.3	Lowering speed, laden/ unladen		m/ s	0.47/0.47
5.4	Reaching speed, laden / unladen		m/ s	0.18/0.21
5.8	Max. gradeability, laden/unladen		%	8/10
5.10	Service brake type			Electromagnetic
Electric engine				
6.1	Drive motor rating S2 60 min		kW	4
6.2	Lift motor rating at S3 15%		kW	8.2
6.3	The maximum allowed size battery		mm	1030×353×784
6.4	Battery voltage/nominal capacity K5		V/ Ah	48V/420Ah ^④
6.5	Battery weight		kg	739 ^④
Addition data				
8.1	Type of drive unit			AC
10.5	Steering type			Electronic
10.7	Sound pressure level at the driver's ear		dB (A)	75

1.The parameters in the table are of the standard model. For more information, please contact us.

2.The parameters are subject to change without notice.

①Service weight (include battery)

Mast height (mm)	Service weight (kg)
2-stage mast	
2700	2665
3000	2675
3300	2685
3600	2695
4000	2705
4300	2715

3-stage mast	
4000	2905
4500	2920
4800	2930
5000	2935
5500	2950

②Mast

2-stage mast			
Lift height	Lowered mast height	Free lift	Extended mast height
h3	h1	h2	h4
2700	1920	0	3640
3000	2070	0	3940
3300	2220	0	4240
3600	2370	0	4540
4000	2570	0	4940
4300	2720	0	5240

3-stage mast			
Lift height	Lowered mast height	Free lift	Extended mast height
h3	h1	h2	h4
4000	1940	1000	4935
4500	2110	1170	5435
4800	2210	1270	5740
5000	2275	1335	5940
5500	2440	1500	6440

③Dimensions(mm)

		2-stage mast	3-stage mast
Overall length (minimum)	l1	2533	2545
Aisle width for pallets 1000×1200 crossways	Ast	2906	2915
Aisle width for pallets 800×1200 lenthways	Ast	2955	2966
Aisle width for pallets 1000×1200 lenthways	Ast	3004	3014
Aisle width for pallets 800×1200 crossways	Ast	2776	2783

④Battery

	Capacity(Ah)	Battery weight (kg)
1	300	600
2	345	560
3	360	620
4	420	739
5	450	739
6	465	739

RATED CAPACITIES GRAPH

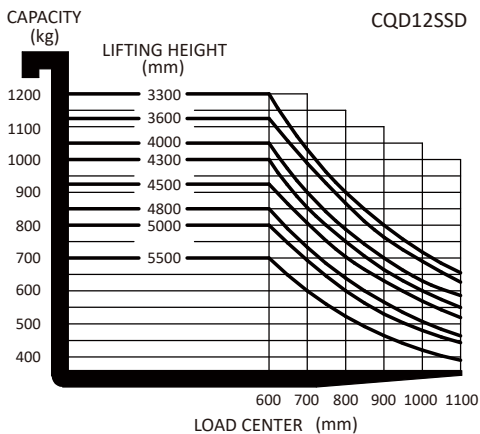

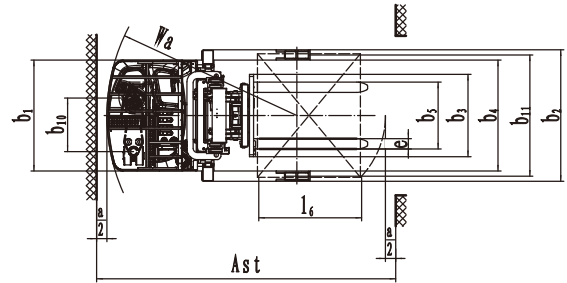
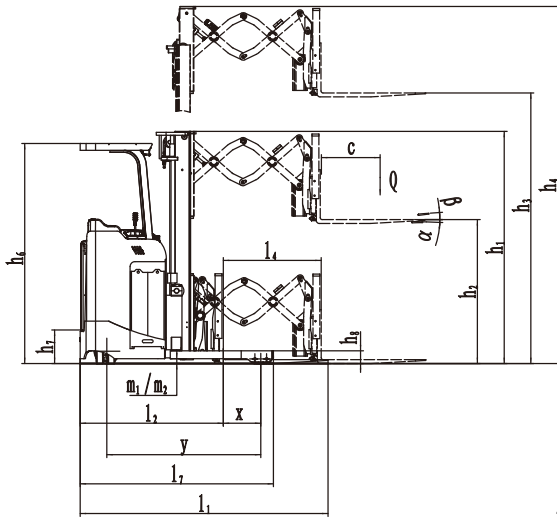

2-stage mast

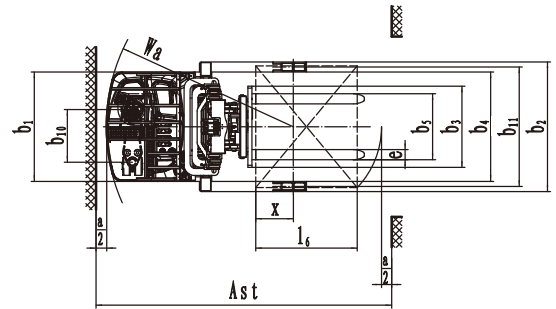
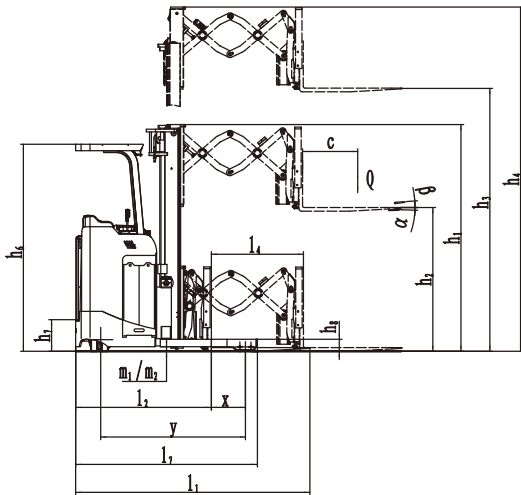

3-stage mast

Option

Options	CQD12SSD
Driving pedal	—
Electronic Power steering	•
Battery capacity	•420Ah ○300/345/360/450/465Ah
Lateral change battery	•
Cold storage	○
Side shift	○
Front light and warning light	•
Rearview mirror	•
Hummer	○
Height display	—
Camera	•
Fire extinguisher	○
The front wheel side guard	—
Drive-in Rack	○
Seat switch	—
Water auto-fillingsystem	○
Note: • standard ○ option — NA	